

Site Surveys – Who Needs One?

An in depth white paper describing the rational and mechanics of a site survey

Introduction

Every time a wireless communications system of any type is installed, it is located in a unique environment. The antenna location, obstructions in the communications path, the relative location and power of nearby communications systems, etc., all combine to form a unique set of conditions. More importantly, these conditions establish a limit on the achievable performance of the wireless system. In some instances, these ‘environmental’ conditions are more significant than the base line performance of the wireless hardware itself in determining real-world performance. The bottom line is that a wireless device’s specifications should never be construed as a guarantee of real-world performance, especially when relating to range. In fact, the age-old adage, “Your actual mileage may vary,” is never truer than when referring to the wireless industry.

However, a Communications Systems Engineer can predict, with reasonable accuracy, the performance of any communications link by first conducting a site survey. This process consists of both passive monitoring of the signal environment, to identify and possibly locate potential interferes, and experimentation with a rapidly deployable communications system to quantify the link parameters. The survey results are then factored in the system design to produce a reliable and dependable communications link.

Survey Mechanics

In-Band Interference Identification

As noted, the first step in the site survey is to evaluate the suitability of the frequency or channel proposed for the communications system. For example, consider the 902 – 928 MHz Industrial, Scientific, and Medical (ISM) Band for unlicensed, low power communications systems. The spectrum analyzer snap shot of this band is shown in Figure 1. The amplitude scale is calibrated to be representative of the anticipated signal levels to be processed by the system’s receiver. In this particular instance, the spectrum appears to be unoccupied, that is, no signals (potential interferes) are observed. Note, however, that this situation is a function of both time and location, hence the survey typically consists of a number of readings.

Figure 1.

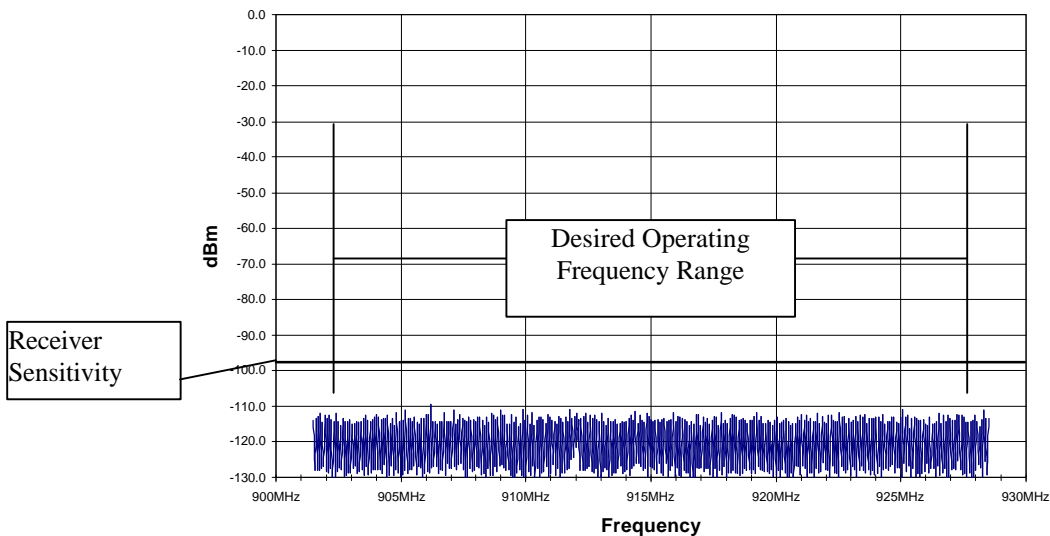

Grayhill Inc.

561 Hillgrove Ave. La Grange Illinois 60525 Phone (708) 354-1040 Fax (708) 354-2820

Site Surveys – Who Needs One?

Now consider the spectrum plot of Figure 2. In this case, the desired signal is shown along with an adjacent interfere. Assuming the interference is caused by a fixed signal source, and the proposed system specifies a receiver at the measurement location, the receiver's ability to reject the interference must be considered. This is a function of the receiver's selectivity performance, which identifies the receiver's ability to reject an interferer as a function of relative signal amplitude and frequency separation. If the selectivity of the receiver is inadequate, the receiver must be moved and/or used with a directional antenna to discriminate against the interferer. The situation is more serious if the interferer is directly on-channel; a directional antenna is the only remedy as the receiver is incapable of distinguishing the interferer from the desired signal (assuming similar signal types).

Unfortunately, not all interferers are fixed in location. For example, in the ISM band, wireless networks can be plagued by a variety of portable devices such as telephones, wireless speakers, remote control units, etc. In general, many of these devices, as well as the network itself, are likely to be spread spectrum systems, so the unique 'spreading codes' of each system offers some inherent rejection to the other. However, even the benefit of the spreading, generally referred to as processing gain, has its limits. At that point the system's frequency agility, or ability to dynamically change frequency to avoid the interference, comes into play. This is obviously a desirable feature in any system.

Another condition that must be explored, and one which is infinitely less obvious, is the possibility of two-tone interference. In essence, when presented with two simultaneous inputs at frequency spacing 'x' the non-linear characteristics of the receiver's input circuitry will generate two additional signals, spaced 'x' away from either of the two inputs. Figure 3 identifies this phenomena known as Third Order Intermodulation Distortion, generally referred to as IMD_3 .

Figure 2.

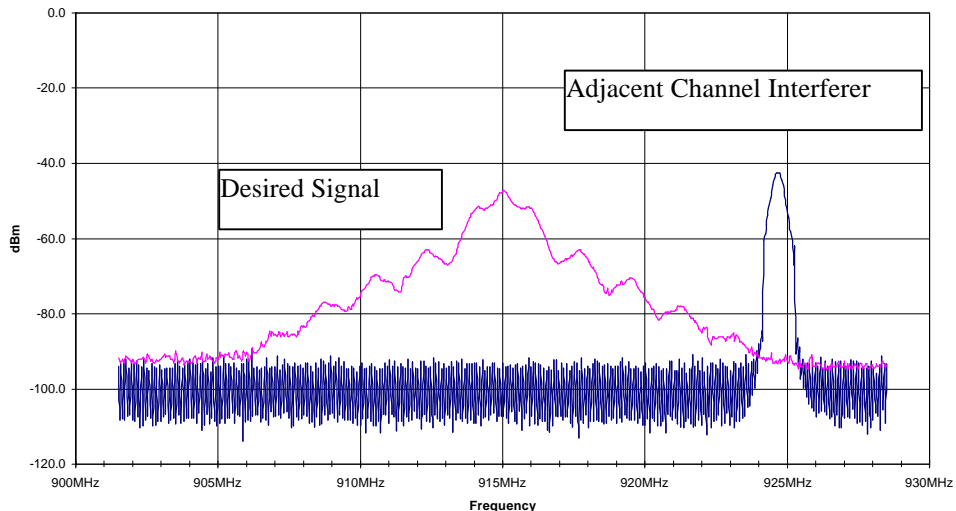

Site Surveys – Who Needs One?

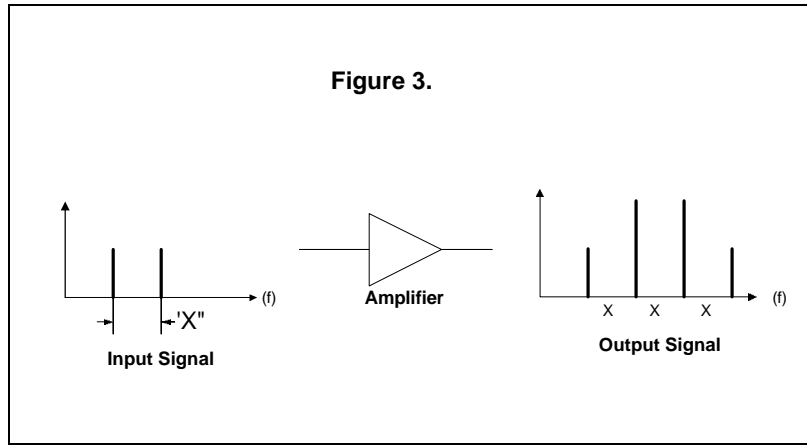

The potential consequence of IMD_3 is that two undesired signals at the receiver's input combine to produce an IMD_3 signal which is on the exact frequency as the desired signal. The result is degraded reception or, depending on the relative amplitude of the IMD_3 signal to the desired signal, no reception at all. Figure 4 compares the performance of two receivers, each presented with the desired signal and two interferers. The first receiver (a), with the superior IMD_3 performance produces at its output an accurate representation of the input signal with no distortion effects: the desired signal can be easily recovered. The second receiver (b), with an IMD_3 specification 5 dB lower, generates two distortion products; the lower frequency component totally obliterates the desired signal, rendering it impossible to recover. Clearly, the number of possible combinations of input signals which might produce an on-channel IMD_3 , signal is staggering. Therefore, the prudent choice is to select a receiver with the best possible IMD_3 performance, specified in dBm.

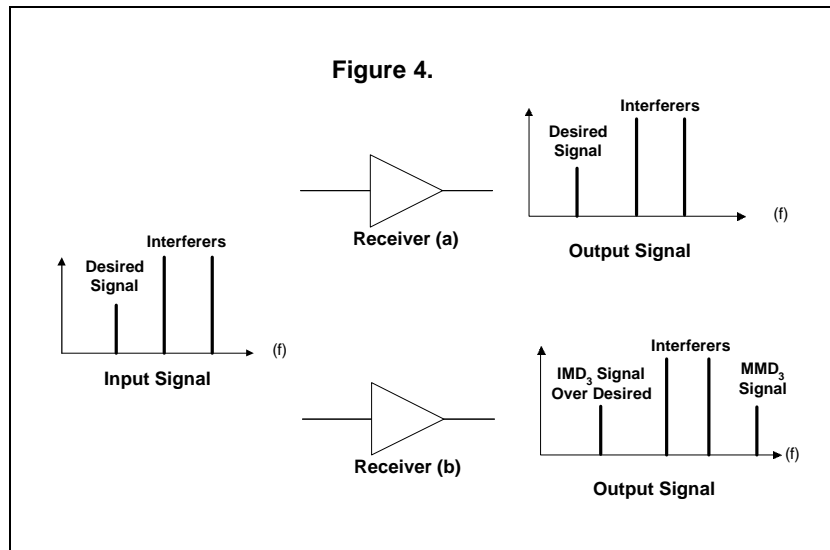

Site Surveys – Who Needs One?

Out-Of-Band Interference Identification

A spectral survey must also include a characterization of the out-of-band signal environment. While this might appear to be a contradiction in terms, out-of-band conditions are frequently more problematic than those in-band. For example, in the ISM band (902 - 928 MHz), the transmitted power levels are limited to 1 Watt, to enable multiple systems to co-exist. However, advanced paging and messaging services are licensed as little as 2 MHz away, in the 930 - 931 MHz band, with transmit power levels approaching 3,500 Watts. Clearly, the 2 MHz frequency separation is not likely to provide adequate protection for an ISM receiver designed to receive the microwatt level signals, which result from a remote 1-Watt transmitter.

The actual effect of a high powered transmitter upon a receiver can be severe: in some cases, the voltage induced into the receiver can cause permanent damage, resulting in a loss of communications. While this may appear 'worst case,' at least the condition is obvious. Of greater concern is the possibility that the interferer 'saturates' the input of the receiver, resulting in a significant loss of sensitivity. Also, as noted previously, some combination of in-band and out-of-band interferers can combine to form an on-channel IMD₃ signal. In all cases, the problem might manifest itself as lost transmissions or an increase in the number of errors detected in the received data.

Moreover, the pager scenario is only one of many real-world conditions, which are encountered on a regular basis. Other potential interferers, ranging from cellular telephones to military navigation systems, are only narrowly separated from the ISM band. As a result, the Communications System Engineer performing the spectral survey must consider both the signal environment and the specifications of the proposed wireless hardware in designing the appropriate network.

Rapidly Deployable System Evaluation

While the primary objective of the spectral survey is to characterize the signal environment, an equally important step is to consider the physical surroundings of the proposed wireless system. For example, an outdoors line-of-sight link presents different problems than an industrial network within a partitioned building. Specifically, the performance of an indoor link is significantly influenced by some building materials, which tend to absorb the signal, and others which act as reflectors. In the latter case the receiver is presented with two identical signals: the direct and the reflected (typically referred to as 'multi-path').

Each of these effects is well understood and can, in fact, be calculate by the Communications System Engineer using a variety of analysis software. However, while genuinely beneficial, this analysis is no substitute for on-site measurements using hardware similar to the proposed system. Accordingly, a site survey includes an evaluation of each prospective link, using the wireless hardware, a number of antenna types, and a data collection system. Figure 5 identifies the components of a typical deployable link used for a site survey.

Figure 5: Rapidly Deployable Wireless Link

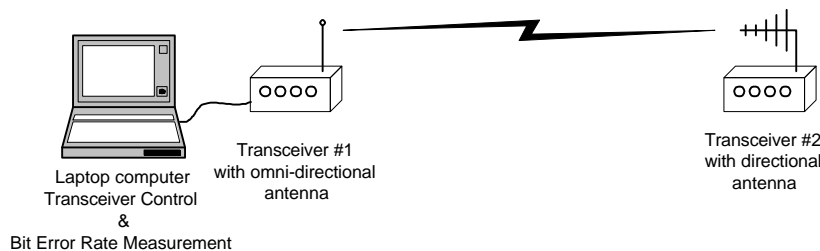

Site Surveys – Who Needs One?

The actual test procedure is very straightforward: a link is established and the system is configured to transfer a pre-defined message from Transceiver #1 to Transceiver #2 (configured as a simple repeater), and back to Transceiver #1. The received messages are then compared with the original transmitted message to determine the number of errors. An attenuator is subsequently inserted between the transceiver and the antenna, with the net effect that both the transmitted and received power levels are decreased. The test is then repeated, with the number of errors noted. This process is repeated until the number of errors obtained exceeds the system's link 'budget.' The value of the attenuator is then used to determine whether the proposed link has adequate 'margin' to operate under all conditions. This is extremely important as link performance can be affected by a myriad of dynamic conditions: weather, intermittent operation of nearby equipment, vehicles and people moving past the antennas, etc.

If the measured link margin is inadequate, some correction action can be taken. First and foremost is the specification of the proper wireless hardware: within the ISM band, a limitation is imposed upon the transmitters output level, so virtually all manufacturers transmitters are equally capable in this area. On the other hand, enhanced receiver performance is available and this frequently can be the difference between a reliable link and no link. The primary specification of interest is receiver sensitivity, specified in dBm; typical numbers range from -90 dBm (average) to -110 dBm (excellent). However, every sensitivity number must be associated with a figure of merit, such as a bit error rate, or the specification is subject to interpretation (and manufacturer 'specsmanship').

For example, consider the case of a conventional FM stereo receiver. Assume that two receivers are offered one with a sensitivity of -100 dBm and another at -105 dBm. The real question is what sound quality each receiver at the stated sensitivity provides. The apparently 'superior' receiver, with a sensitivity of -105 dBm, may produce a barely intelligible, noisy speaker output for the stated input, while a -100 dBm signal into the 'inferior' unit might provide full stereo, noise-free music. Suddenly, the relationship between the units' sensitivity specifications and the actual performance is less clear.

The digital wireless domain is no different. In fact, virtually any receiver will produce SOME output for an input of -100 dBm. Therefore, the question is, how usable is that output? The bottom line is that an apples-to-apples comparison can only be made when receivers are compared using a common metric, such as Bit Error Rate (BER). BER is generally specified as errors per million bits. Resulting in specifications such as 1×10^{-6} or $1E-6$ (for 1 error per million bits), and 1×10^{-5} or $1E-5$ (for ten errors per million bits).

Another variable worth noting is Forward Error Correction (FEC). Using advanced signal processing, some units can actually detect errors and then correct them. This provides another degree of freedom to the Communications System Engineer in designing a wireless system. For instances if the system constraints (data rate, location, interferer scenario, etc.) prevent the link from achieving the required error rate performance, he can specify a device which includes FEC. Deploying a temporary link with switchable FEC will confirm whether FEC is truly required.

Site Surveys – Who Needs One?

Transceiver Specifications

By combining a spectral survey with hardware evaluation, the site survey can be used to determine the suitability of the wireless network for the proposed location. However, as noted with regard to sensitivity, intermodulation distortion, FEC. etc., the link performance is clearly dependent upon the specifications of the transceiver (though not exclusively). Accordingly, the following guidelines are presented:

Typical Transceiver Specifications

Parameter	Typical Specification	EZ Com Performance	Comments
Sensitivity @ 1E-6 BER	-105 dBm @ 1E-6 BER	-104 dBm	A lower number indicates improved sensitivity. Look for associated Bit Error Rate (BER) figure of merit.
Noise Figure	5 dB to 9 dB	5.5 dB	A lower number reflects less internally generated noise and results in improved sensitivity
Third Order Intermodulation Distortion (IMD ₃)	-30 dBm to +5 dBm	+4 dBm	Poor performers (negative numbers) are susceptible to jamming by adjacent channel signal sources.
Phase Noise	-95 dBc/Hz to -75 dBc/Hz	-90 dBc/Hz	Not often specified, but an indicator of the spectral purity of internal signal oscillators, resulting in improved BER performance. Higher (negative) numbers are desirable.
Image Rejection	60 dB to 80 dB	75 dB	Identifies receiver's ability to discriminate against interfering signals separated from the desired signal by a fixed offset, which is a function of the receiver's design. Higher numbers are desirable.
Out-Of-Band Rejection	15 dB to 40 dB	30 dB	Receiver's rejection of pagers (929MHz) and cellular telephones (895MHz)

Conclusion

Designing a wireless communications system is a routine task for the experienced Communications Systems Engineer, but a recipe for disaster for a novice. Successfully deploying an information-critical network requires considerable experience, not to mention sophisticated instrumentation and measurement equipment, to ensure that the link performance is designed in and not left to chance. Who needs a Site Survey? You do! (Bottom line: kids don't try this at home!)