

P89C66x Microcontroller

P89C660, P89C662, P89C664



The P89C66x family is available in 44-pin PLCC and LQFP package types

Key Features

- More data RAM - up to 2 K bytes
- Supports the I²C serial interface
- Twice the speed of the conventional 80C51
- Flash In-System and In-Application Programmable
- Programmable counter array
- Watchdog timer
- Pin-compatible with 8xC652, 8xC654, 8xC528

P89C66x Product Family

Device	Flash Program Memory	RAM
P89C660	16 K bytes	512 bytes
P89C662	32 K bytes	1024 bytes
P89C664	64 K bytes	2048 bytes

Description

The P89C66x, based on the 80C51 family, has up to 64 KB of Flash program memory and is set apart from other 80C51 derivatives with I²C and RAM capacity up to 2048 bytes. The P89C66x RAM to ROM ratio meets the designer's requirement for large data memory when writing C code.

The Flash program memory of the P89C66x supports both parallel programming and 5 V serial ISP. Parallel-programmable means the devices can be gang-programmed at high speed, thus reducing programming costs and time to market. A default serial loader (boot loader) program in ROM allows serial ISP of the Flash memory without the need for a loader in the Flash code. ISP allows a device's program memory to be altered in the actual end product. The capability to field-update the application firmware makes a wide range of applications possible.

In addition, the P89C66x is In-Application Programmable (IAP). Because the 66x contains a boot ROM, the Flash program memory can be reconfigured even while the application is running. User programs may erase and reprogram the Flash memory at will through the use of standard routines contained in ROM. With IAP, the application can be updated remotely with changes or enhancements in the field even while the application is running, so there is no downtime or interruption of service.

A key feature of the P89C66x is its fast execution. The design engineer can choose to run the application with the conventional 80C51 clock rate (12 clocks per machine cycle) or use the default mode (six clocks per machine cycle) to achieve a 2x throughput improvement with the same clock frequency. Another way to benefit from this feature is to keep the same throughput by reducing the clock frequency by half, thus dramatically reducing electromagnetic interference. So, a 20 MHz P89C66x becomes a 40 MHz equivalent microcontroller.

The P89C66x is suitable for a wide variety of applications that benefit from low EMI and the flexibility of Flash ISP and IAP. It also supports applications that require pulse width modulation, high-speed I/O and/or up/down counting capabilities such as motor control. Because the P89C66x family has I²C, it is also extremely well suited for Intelligent Platform Management (IPMI) applications in servers and high-end PCs where I²C serves as physical protocol for the interface.

Features

- Familiar, industry standard 80C51 architecture
- On-chip 5 V Flash program memory
 - In-System Programming (ISP)
 - In-System Programming (ISP)
 - Boot ROM enables erasing and reprogramming in the end product through the serial port
 - In-Application Programming (IAP)
 - Boot ROM enables application to control programming
 - Block programmable—an application runs in one block while another is being reprogrammed
- Fast execution
 - X2 mode—6 clocks per machine cycle
 - 20 MHz (40 MHz 80C51—equivalent throughput)
 - Conventional mode—12 clocks per machine cycle—33 MHz
- 4.5 V to 5.5 V operating range
- Large data memory for C-programming
- Four 8-bit I/O ports
- Three 16-bit timer/counters
- RAM expandable externally to 64 KB
- Dual data pointer
- I²C serial interface
- Full-duplex enhanced UART
- Interrupts
 - Seven interrupt sources
 - Four level priority interrupt
- Programmable clock out
- Programmable Counter Array (PCA)
 - High-speed output
 - Capture and compare
 - Pulse Width Modulator (PWM)
 - Watchdog timer option
- Hardware watchdog timer (one-time enabled with reset-out)
- Power control modes
 - Fully static operation
 - Idle mode
 - Power down mode
- Low EMI (inhibit ALE)
- Industrial and commercial temperature grades
- 44-pin PLCC and LQFP

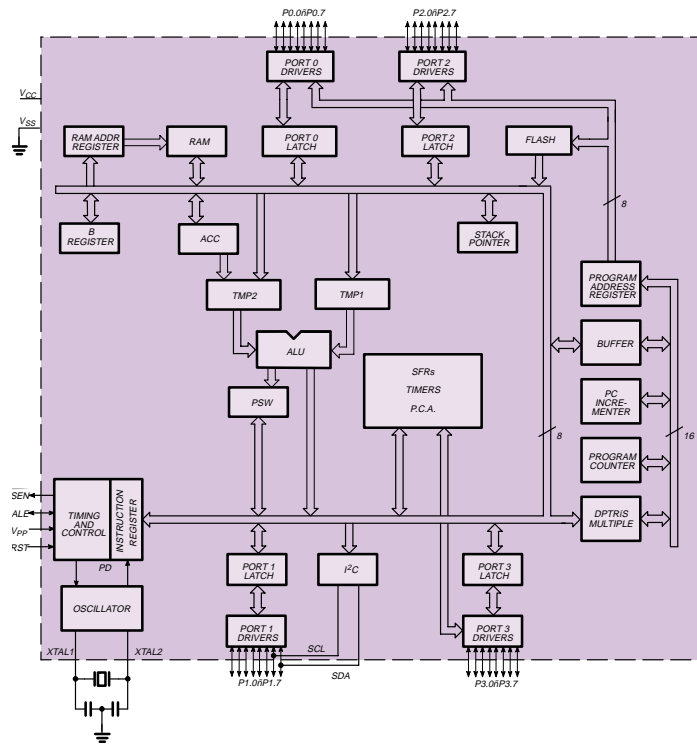

Ordering Information

Part Number	Package	Temperature
89C660 Flash Microcontroller with 16 KBytes Flash and 512 Bytes RAM		
P89C660HBA	PLCC44	0 to +70 C
P89C660HFA	PLCC44	-40 to +85 C
P89C660HBBD	LQFP44	0 to +70 C
89C662 Flash Microcontroller with 32 KBytes Flash and 1024 Bytes RAM		
P89C662HBA	PLCC44	0 to +70 C
P89C662HFA	PLCC44	-40 to +85 C
P89C662HBBD	LQFP44	0 to +70 C
P89C662HFBD	LQFP44	-40 to +85 C
89C664 Flash Microcontroller with 64 KBytes Flash and 2048 Bytes RAM		
P89C664HBA	PLCC44	0 to +70 C
P89C664HFA	PLCC44	-40 to +85 C
P89C664HBBD	LQFP44	0 to +70 C
P89C664HFBD	LQFP44	-40 to +85 C

All above devices operate according to the following specifications:
 4.5 to 5.5 Volts for parts rated 0 to +70C
 4.75 to 5.25 Volts for parts rated -40 to +85C
 0 to 20 MHz @ 6-clock operation
 0 to 33 MHz @ 12-clock operation

For more information, contact your Philips Semiconductors distributor or www.PhilipsMCU.com

North America

Tel: 1 800 234-7381

Internet:

www.PhilipsMCU.com

Europe

Fax: +31 79 3685126

Asia

Fax: 886 2 2134-2941

Japan/Korea

Fax: +81-3-3740-5057

Internet (in Japanese):

www.philips.co.jp/semicon/

© Philips Electronics N.V. 2000

All rights reserved. Reproduction in whole or in part is prohibited without the prior written consent of the copyright owner. The information presented in this document does not form part of any quotation or contract, is believed to be accurate and reliable and may be changed without notice. No liability will be accepted by the publisher for any consequence of its use. Publication thereof does not convey nor imply any license under patent - or industrial or intellectual property rights.

Printed in the USA 611651/20K/FP/2pp/1200

9397-750-7809